

CERTIFICATION



HACCP International



ISO9001

ICE MATE



SRM-200AB -B-301SA

ICE MAKER

DICE

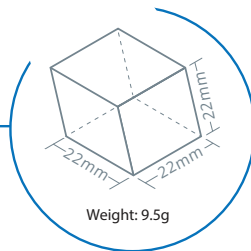

ICEMATE is committed to bringing high-efficiency / energy-saving, and high quality ice-making product to people who have dreams and desire to create their own business with the best scientific technology and manufacturing technology.

KEY FEATURES

SAFETY AND HYGIENE ASSURED ICE MACHINE

AUTO-CLEANING



Timely maintenance of water system can extend life of equipment.

PURE ICE



Overflow self-cleaning function, ensuring ice hygiene

IoT



Slow melt Dilution

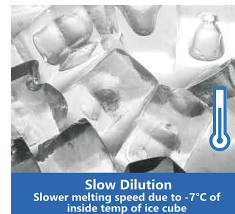

Slow Dilution
Slower melting speed due to -7°C of inside temp of ice cube

Powerful Ice Making



Energy & Water Saving, Quiet Operation

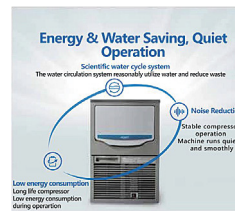

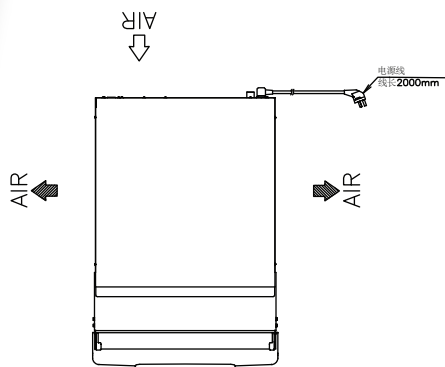

BIN TOP VIEW

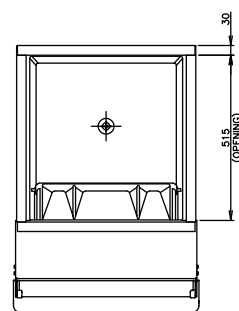

RIGHT SIDE

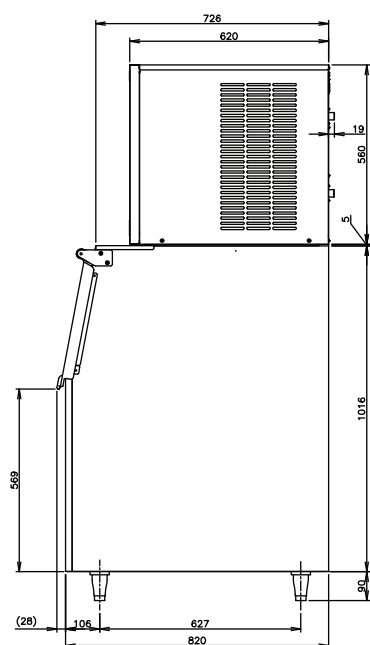

BACK SIDE

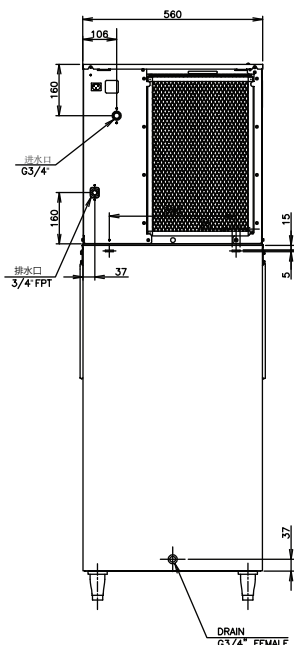

FRONT SIDE

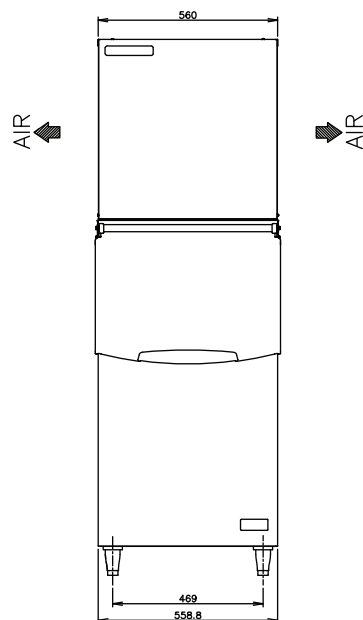

SPECIFICATIONS

Ice Dimensions (W x D x H)	22 x 22 x 22 mm
Outside Dimensions (W x D x H)	560 x 820 x 1671(~1701) mm
Package Dimensions (W x D x H)	Ice Maker: Pallet+Carton: 650 x 710 x 750mm Storage Bin: 655 x 924 x 1138 mm
Weight (Net / Gross)	Ice Maker: 50kg / 66.5kg Storage Bin: 37kg / 49kg
Amperage / Starting Amperage	5.6A / 22A
Electrical Consumption	(AT32°C / WT21°C) 835W
Refrigerant Charge	R404A/450g
Ice Storage Capacity	Maximum 144 kg
Ice Production per 24H	(AT10°C / WT10°C) Approx. 201 kg (AT21°C / WT15°C) Approx. 174 kg (AT32°C / WT21°C) Approx. 130 kg

Water Consumption per 24H	(AT32°C/WT21°C) 0.14m ³ (1.1 L / kg Ice)
Ice Production Freeze Cycle Time	(AT21°C/WT15°C) 13.3 min
Ice Production per Cycle	(AT21°C/WT15°C) Approx. 1.72kg / 182 pcs

OPERATING CONDITIONS	
Voltage Range	198 - 242 V
Ambient Temperature	5 - 38°C
Water Supply	5 - 32°C
Water Supply Pressure	0.07 - 0.55 Mpa (0.7 - 5.5 bar)
Supply Voltage	1/220 - 240V / 50Hz

